

Nilfisk

C 120.4 - C 120.4 X-Tra

E 130.2 - E 130.2 X-Tra

E 140.2 - E 140.2 X-Tra



Repair Manual

Nilfisk

A. Safety Issues 3

B. Technical data 4

C. Construction 5-9

D. Service /Repair 10-18

E. Operation. 19-28

F. Diagram 29-30

Safety precautions

- **WARNING!** High pressure jets can be dangerous. Never direct the water jet at persons pets, live electrical equipment or the machine self.
- The operator and anyone in the immediate vicinity of the site of cleaning should take action to protect themselves from being struck by debris dislodged during operation. Wear goggles during operation.
- Never try to clean clothes or footwear on yourself or other persons.
- Do not let children or people who have not read the instruction manual operate the machine.
- Never use the machine in an environment where there could be a danger of explosion. If any doubt arises, please contact the local authorities.
- It is not allowed to clean asbestos- containing surfaces with high pressure.
- This high pressure washer must not be used

Product segment: Consumer		C 120.4 X-tra	E 130.2 X-tra	E 140.2 X-tra
Specification	bar	120	130	140
Voltage	V	230	230	230
Frequency	Hz	50	50	50
Power consumption	A	9	9,5	10
Power absorbed	KW	1,7	2,1	2,1
Numbers of revolutions	rpm./ min.	2800	2800	2800
Water volume, HP	l / min.	6	6,9	6,5
Pump pressure	bar	100	112	121
Nozzle pressure	bar	94	106	115
Opening pressure	bar	140	140	140
Retaining time	min.	5	5	5
Oil contents	ml	110	110	110
Oil type		Bartran HV46	Bartran HV46	Bartran HV46
Max water inlet temperature	C	40	60	60
Max water inlet pressure	bar	10	10	10
High pressure hose length	m	6m Textile	8 or 9m textile	9m textile or 10m steel
Suction height	m	1m wet	1m wet	1m wet
Electric cable	m	5m	5m	5m
Insulation class		F	F	F
Tightness		IPX5	IPX5	IPX5

C 120.4 Construction of cabinet parts.

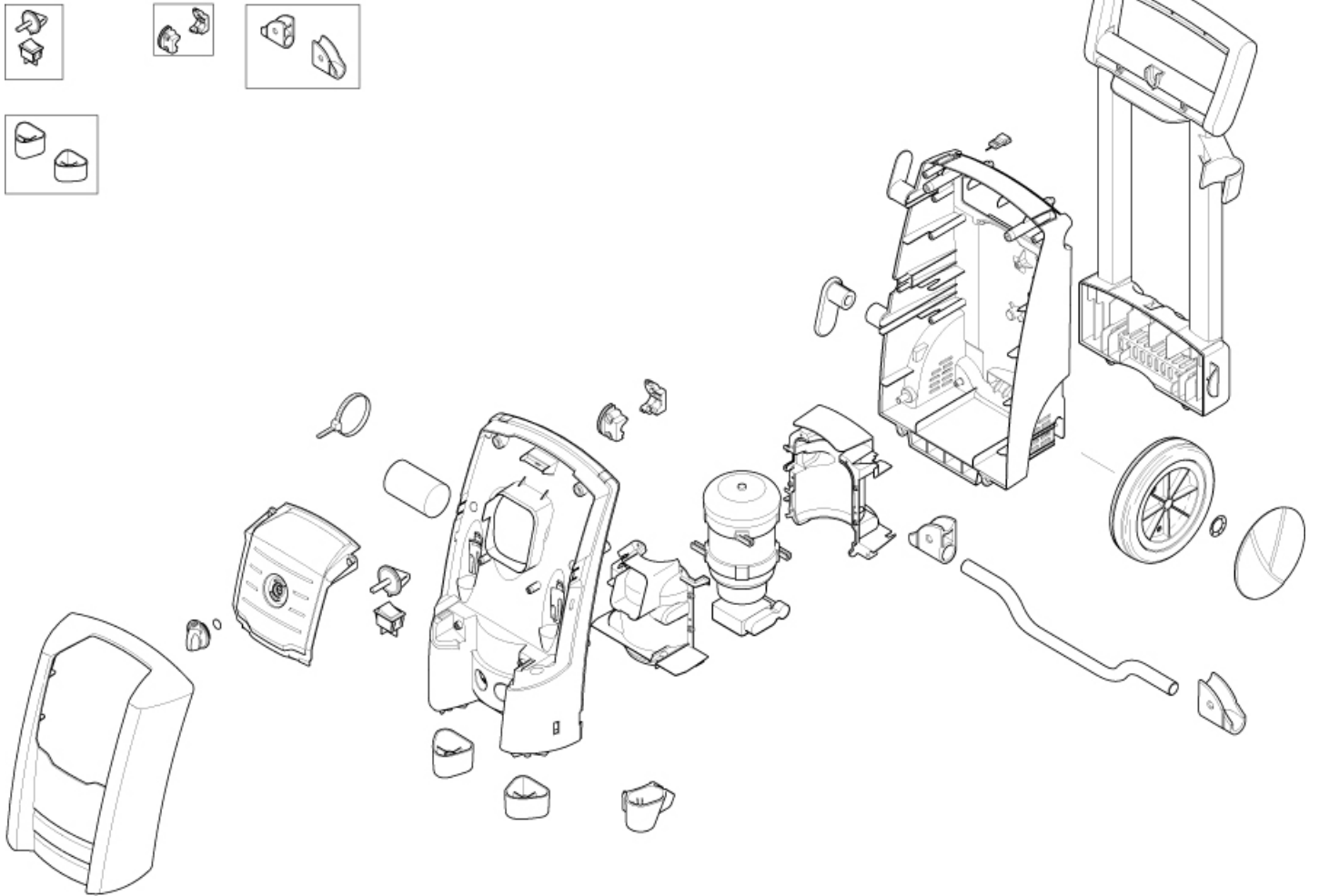

E 130.2 X-tra - E 140.2 X-tra Construction of hose reel.

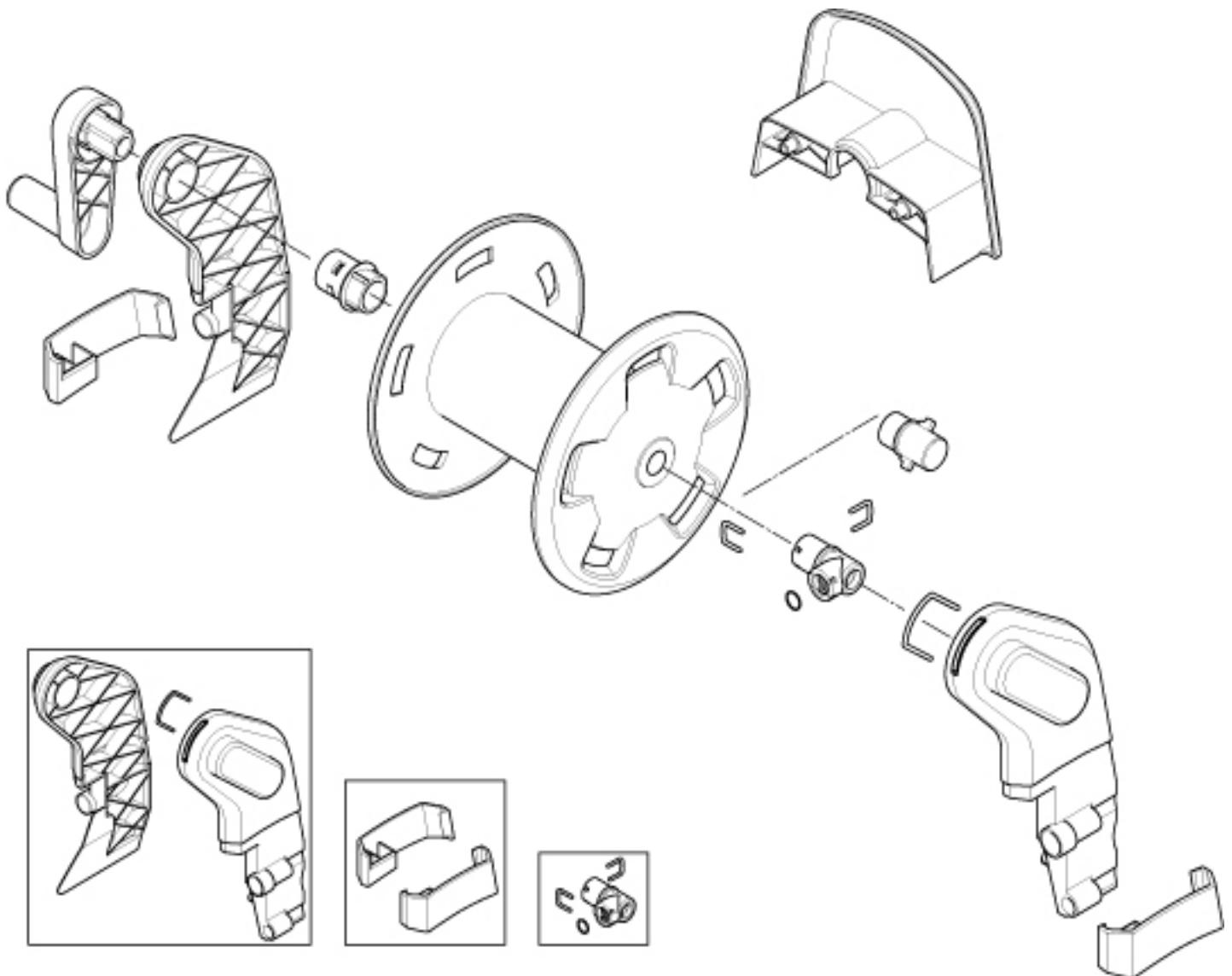

E 130.2 - E 140.2 Construction of cabinet parts

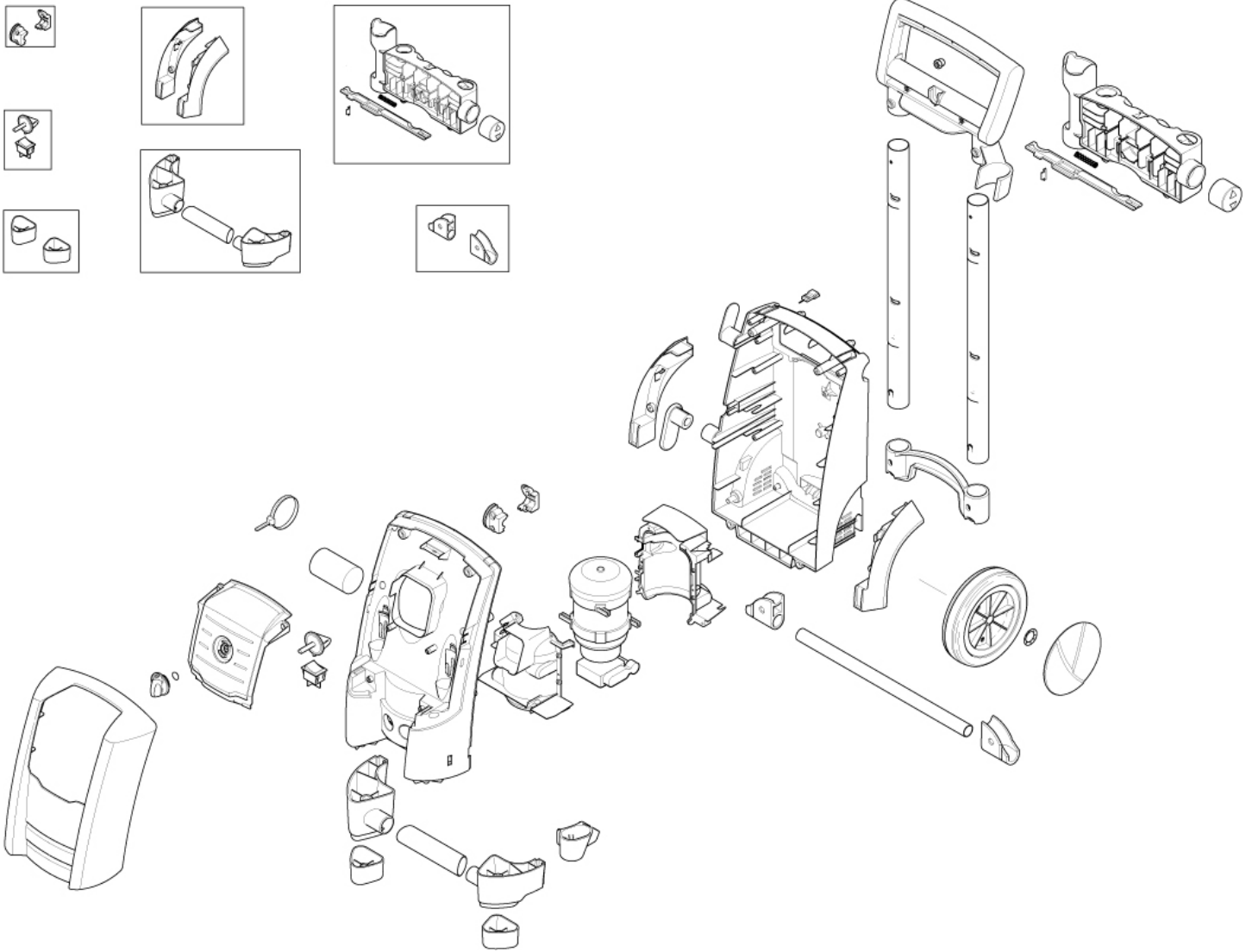

C 120.4 E 130.2 E 140.2 Construction of motor pump unit.

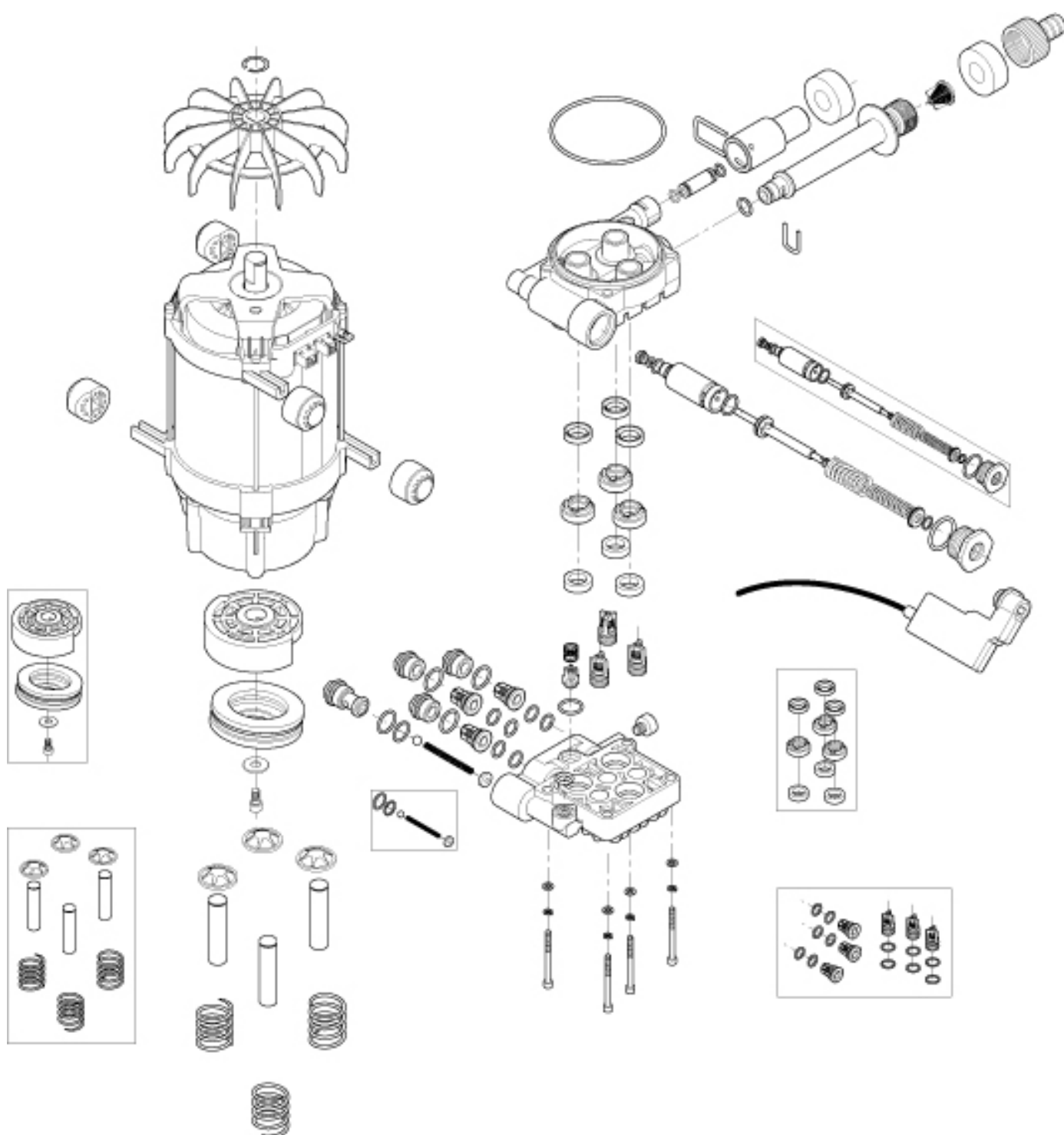

C 120.4 X-tra - E 130.2 X-tra - E 140.2 X-tra Construction of motor pump unit.

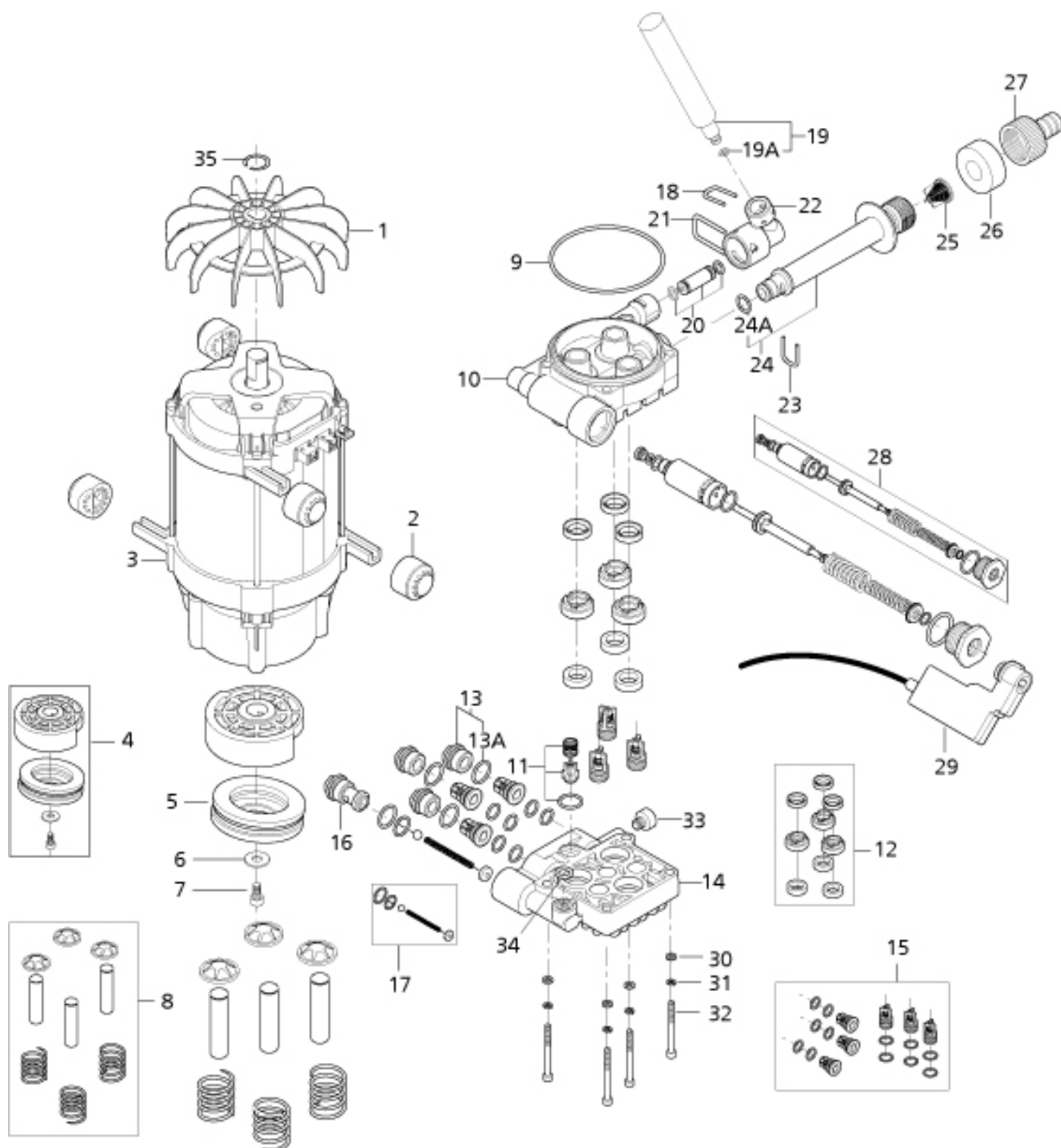

Dismounting / mounting of front cabinet and front chassis.

Remove 4 torx Screws (TX 20)(fig.1) and then 2 torx Screws (fig.2). Then use a small screwdriver to tip out the cabinet. (fig.3). Remove 6 torx screws in the front chassis (fig.4) and 2 screws at the bottom (fig.5)

Fig.1

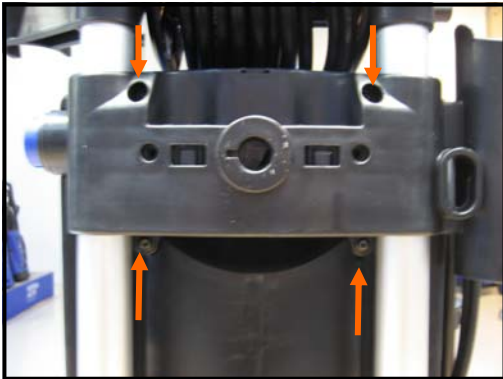

Fig.2

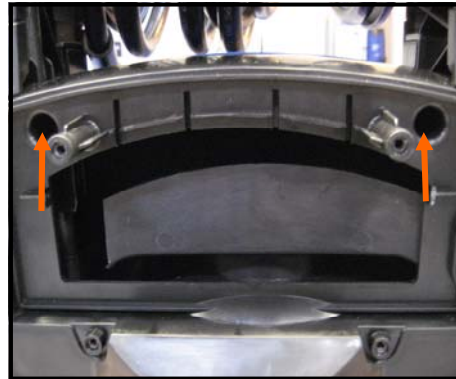

Fig.3

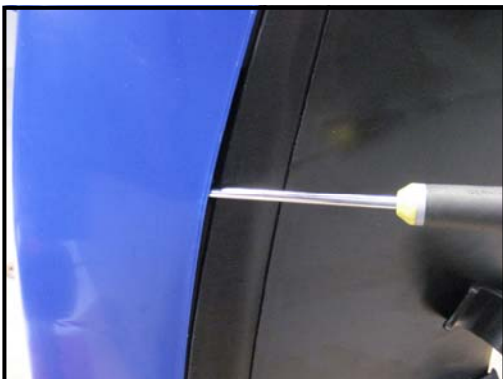

Fig.4

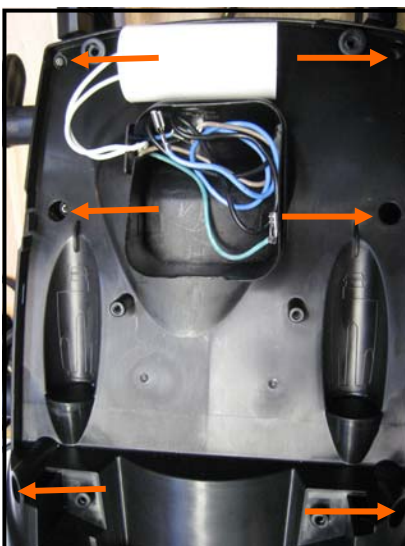
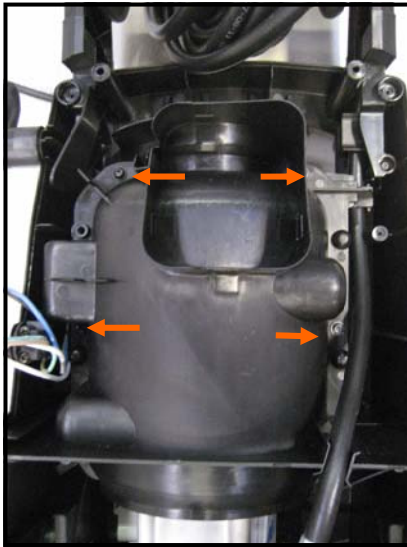
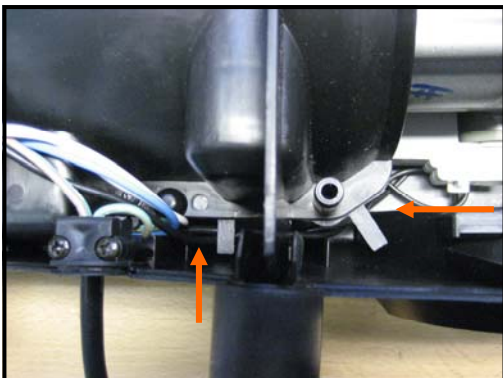
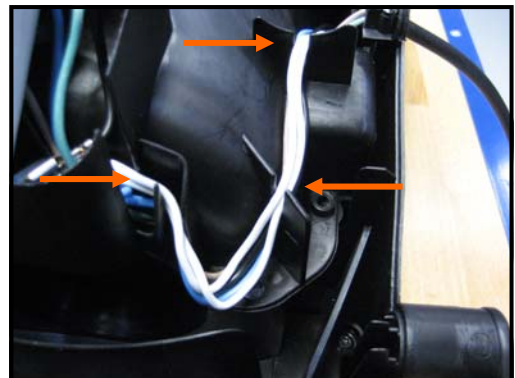

Fig.5



Dismount / Mounting of Motor cover.

Remove 4 torx (TX20) screws . (fig.1) When mounting the motor cover and front chassis be sure that the wire are in the right position. (fig.2 and 3)

Fig.1**Fig.2****Fig.3**

Dismounting / Mounting of S/S valve.

Remove micro switch box carefully with 2 screw driver (fig.1) and then the S/S valve (fig.2.) Mount the micro switch (fig.3) and press down the micro switch arm with a screwdriver (fig 4).

Fig.1

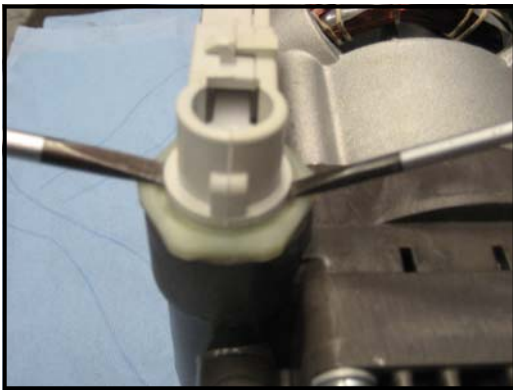

Fig.2



Fig.3



Fig.4

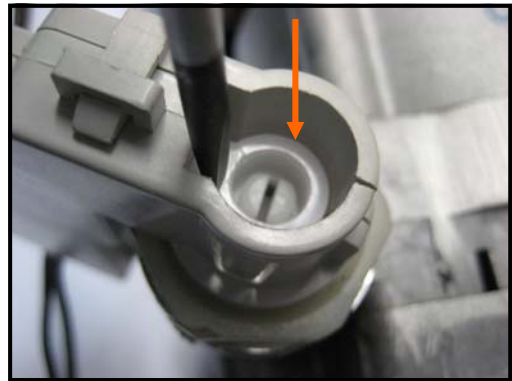

Dismounting / mounting of oil seal.

Tip up the oil seal with a screwdriver and discard (fig.1).

Clean up and lubricate.

Mount a new oil seal.

Fig.1

Dismounting / mounting of suction and pressure valves.

Remove valve seat with tool and discard them (fig.1 and 2). Mount new valves with a slight finger pressure and special tool no.1220103 (fig 3 and 4). Clean up and lubricate before mounting.

Fig.3

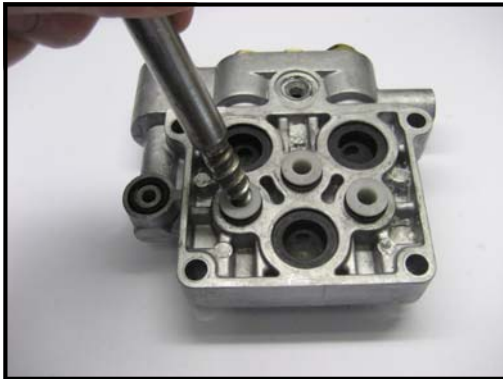

Fig.2

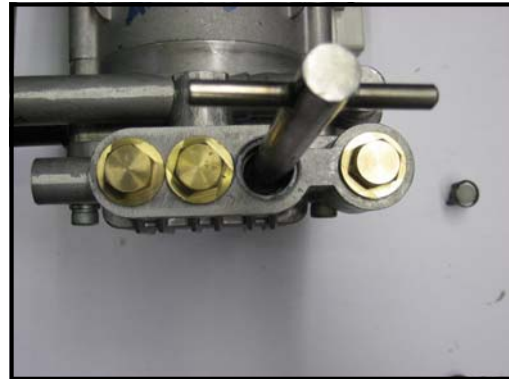

Fig.3

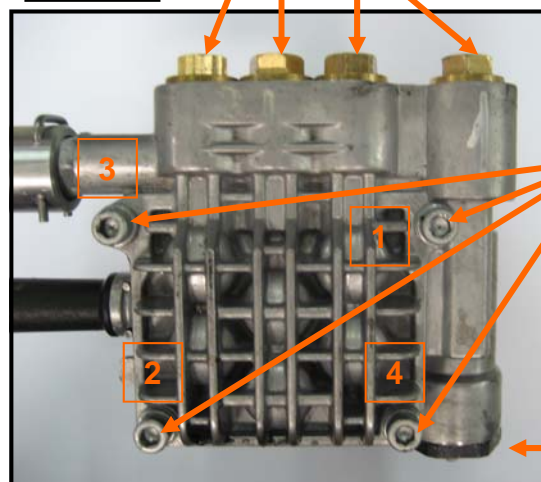

Fig.4



Use loctite 271— torque 20 Nm

Fig.5



When mounting the cylinder head you have to tighten the bolts in this order see (fig.5)

Torque 16 Nm

Torque 10 Nm

Fig.1



Bearing track on fig.1 and fig 2 are different.
(inner diameter are different)

Be sure it fits to the wobble disc.

Fig.2



Wobble Disc marking and assembling

120 bar "1-1" or "6,6°-1"

130-140 bar "2-1" or "7,5°-1"

Fig.3



Dismounting / Mounting of Easy start valve.

Remove the easy seat with a small hook (fig.1) then remove the o-ring underneath the seat ,with a small screwdriver .

Mounting : place the ball on the end of the spring (fig.2), be sure the the ball are in the right position when mounting plug.

Fig.1

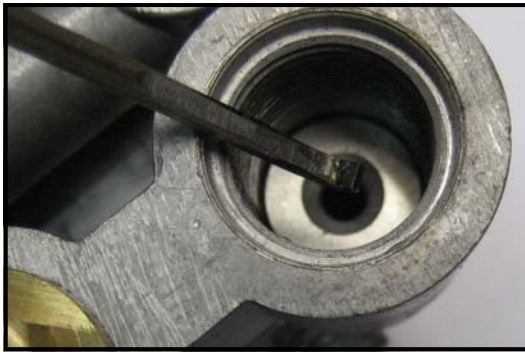

Fig.2

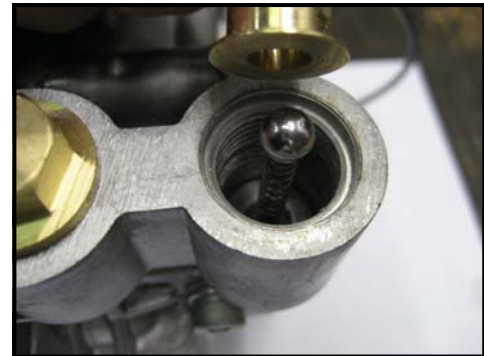
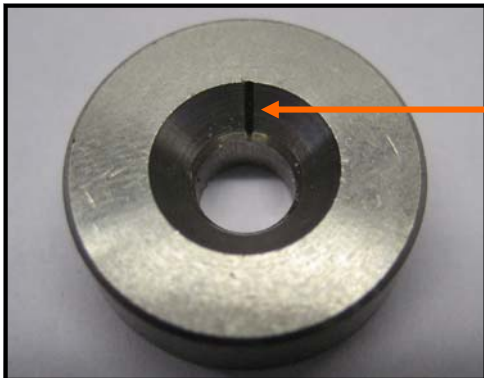

Fig.1



Regarding the mark on the seat,
See section "Operation guide"
2.5 Handle release



Torque.

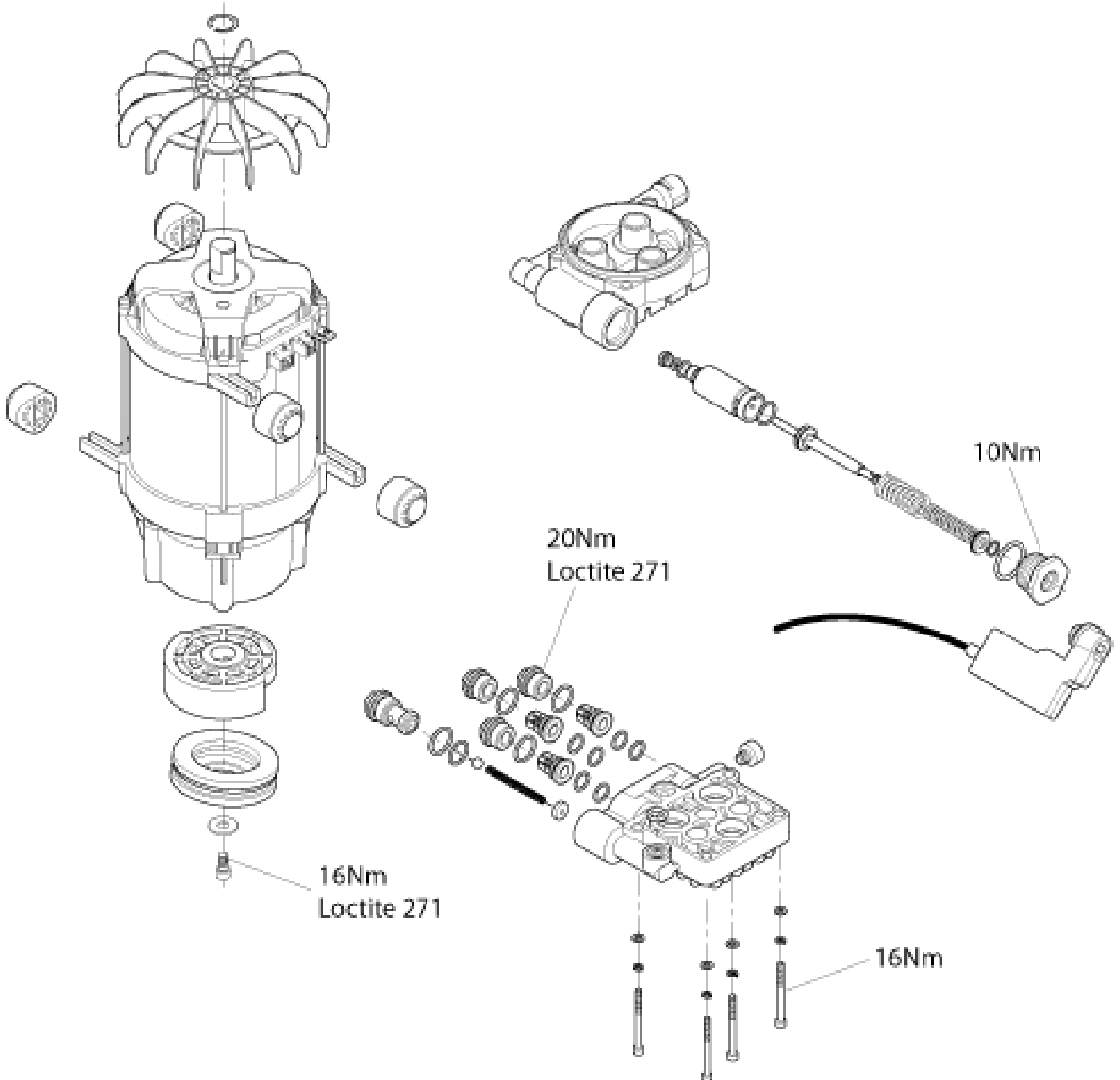

Guidance of measuring of electrical motor.

1,7 KW Motor

1. 6,1 ohm.
2. 8,9 ohm.
3. 2,8 ohm.

2,1 KW Motor

1. 7,1 ohm.
2. 8,9 ohm.
3. 1,8 ohm.

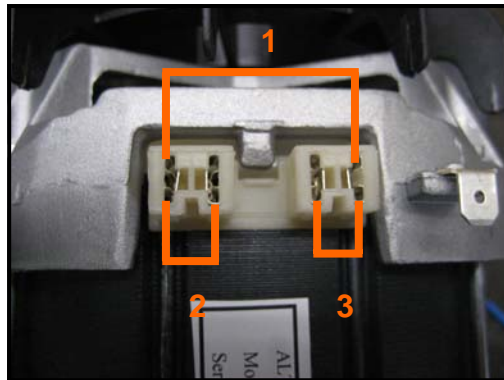

Capacitor Plug.

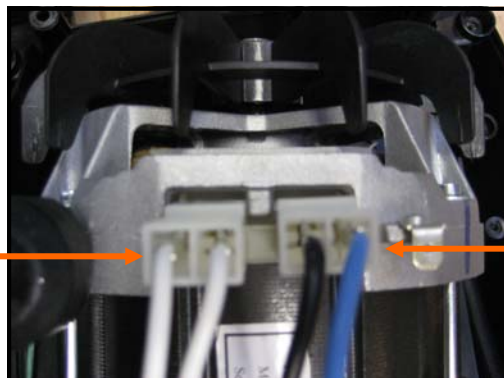

Power supply Plug.

2.0 Operation

2.1 Machine stopped and outlet hose emptied

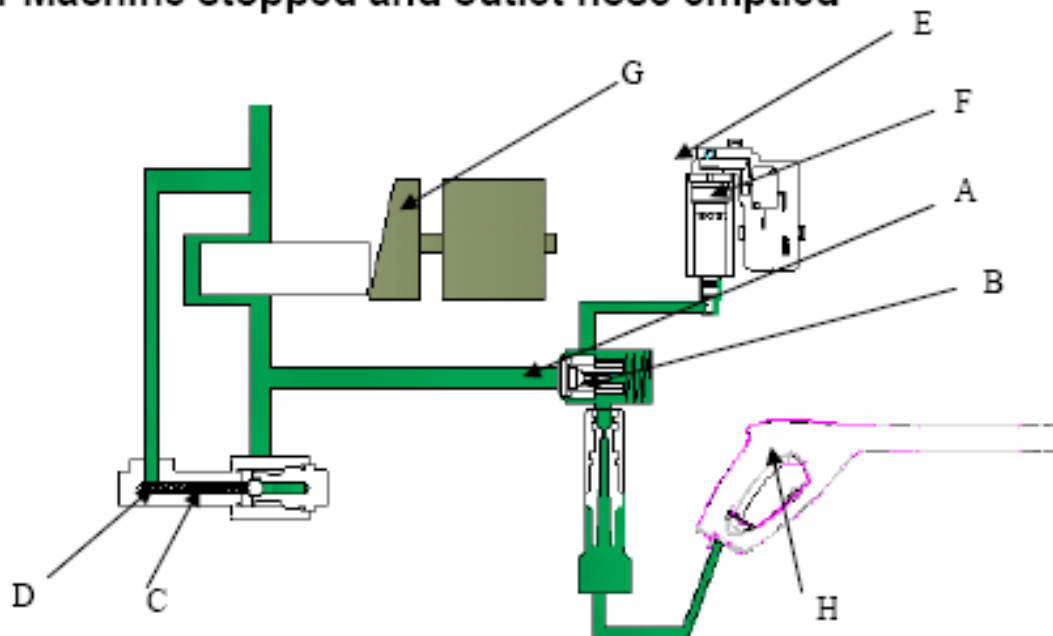

In this situation the position of the parts are following:

The non return valve (A) is closed by the spring (B) as there is no pressure on either of the sides. The easy start ball valve (C) is pressed against the upper seat by the easy start spring (D). The s/s spring pressed the s/s piston, and the Activation arm (E) is taken to the front position the micro switch (F) at the "switch on" position, the motor (G) will start. The handle (H) is released, No water flow from the nozzle.

Water flow: None

2.2 Starting up when connecting the machine (soft start)

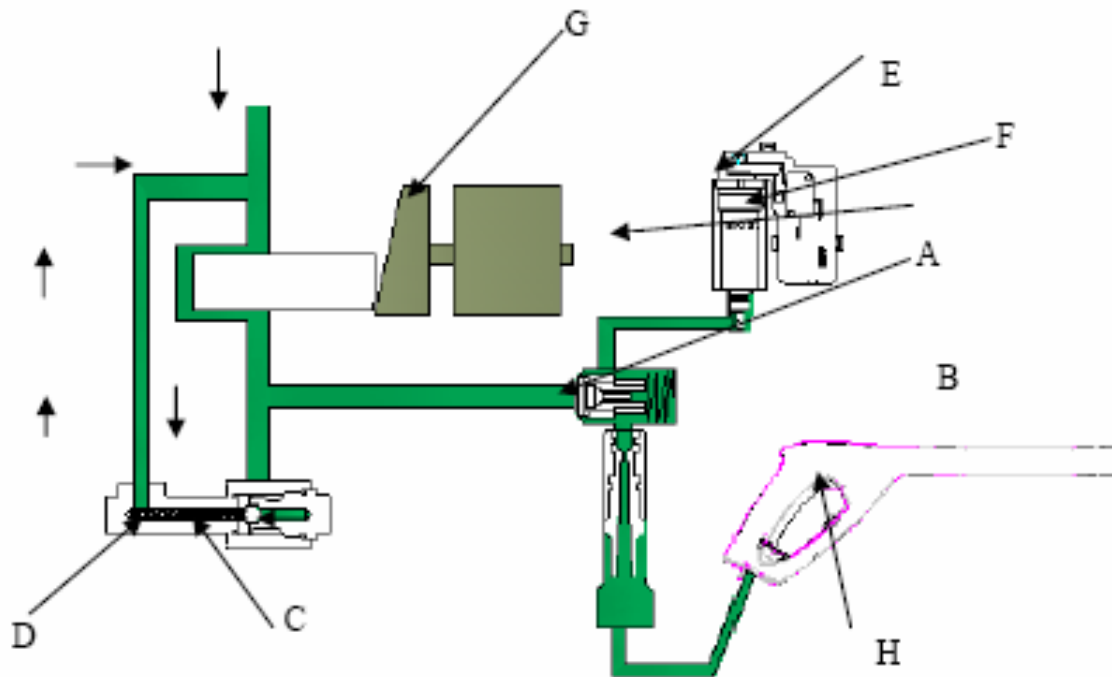

1. The non return valve (A) is closed by the spring (B) as the pressure on the front side is still not high enough to open it.
2. The easy start ball valve (C) moves a little from the upper seat as the easy start spring (D) is pressed a little.
3. The s/s spring pressed the s/s piston, and the Activation arm (E) is taken to the front position, the micro switch (F) at the "switch on" position, the motor (G) is running.
4. the handle (H) is released, and no water flow from the nozzle.

Water flows:

1. From the water inlet to the pump.
2. From the pump through the ball valve to the water inlet.

2.3 Building-up of pressure in hose

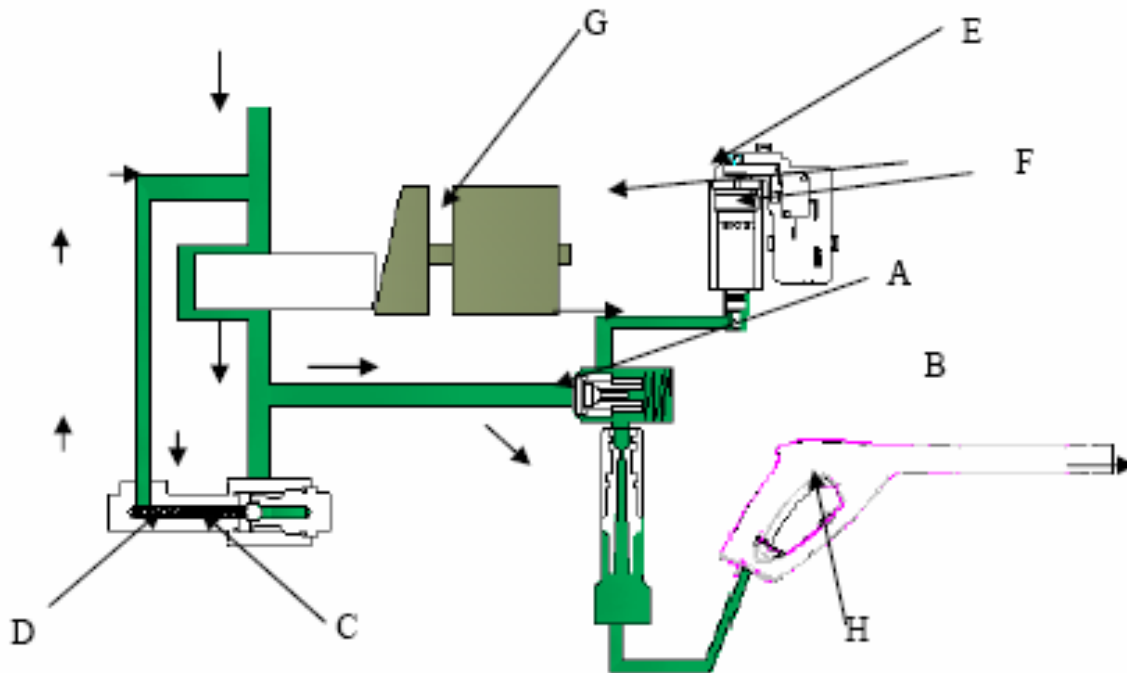

During building-up of pressure, the position of the parts are following:

1. The non return valve (A) open a little because of the high pressure from pump.
2. The easy start ball valve (C) moves to the lower seat as the easy start spring (D) impressed more.
3. The s/s spring pressed the s/s piston, and the Activation arm (E) is taken to the front position, the micro switch (F) at the "switch on" position, the motor (G) is running.
4. The handle (H) is released, and no water flow from the nozzle

Water flows:

1. From the water inlet to the pump
2. (Decreases during the process). From the pump through the ball valve to the water inlet
3. From the pump through the non-return valve to the high pressure hose.

2.4 Operation

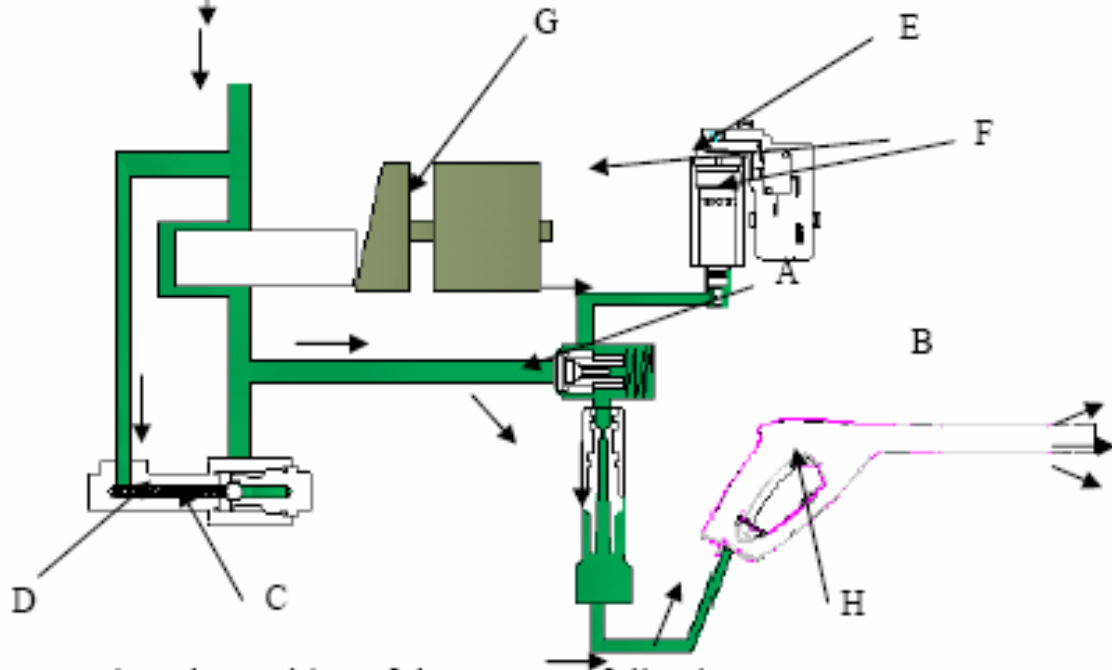

1. The non return valve (A) is fully open because of full working pressure and flow.
2. The easy start ball valve (C) is pressed against the lower seat by the pressure from the pump.
3. The s/s spring is pressed a little , but the Activation arm (E) is still on the front position, The micro switch (F) at "switch on" position. The motor (G) is running.
4. The handle (H) is activated, and water flow from the nozzle.

Water flows:

1. From the water inlet to the pump.
2. From the pump through the non-return valve to the high pressure hose.

2.5 Handle release

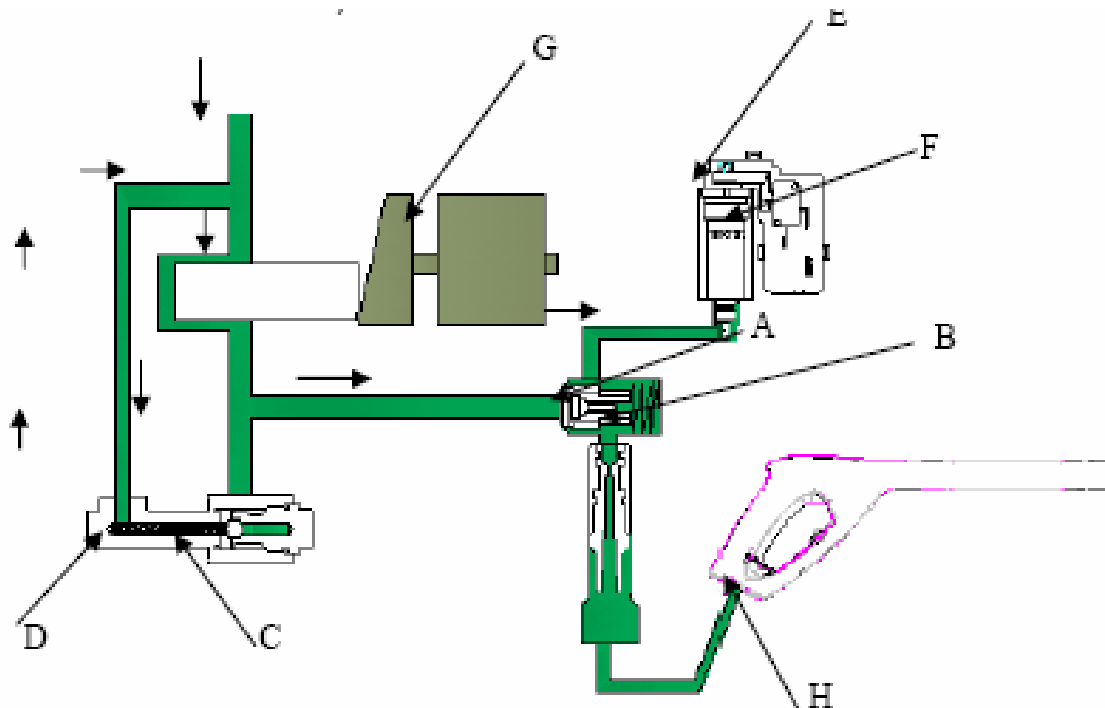

1. The non return valve (A) is closed by the pressure in the hose system.
2. The s/s spring is pressed at max position, the Activation arm (E) moves back, presses the Micro switch (F) at "switch off" position (means that the motor (G) is stopped).
3. The pressure in pump drop over a leak in the easy start valve, The easy start spring presses the ball valve (C) up against the upper seat, pressure in the cylinder head close to the inlet pressure.
4. the handle (H) is released, and no water flow from the nozzle

Water flows:

None

3.0 Start stop system guide

3.1 No pressure in system

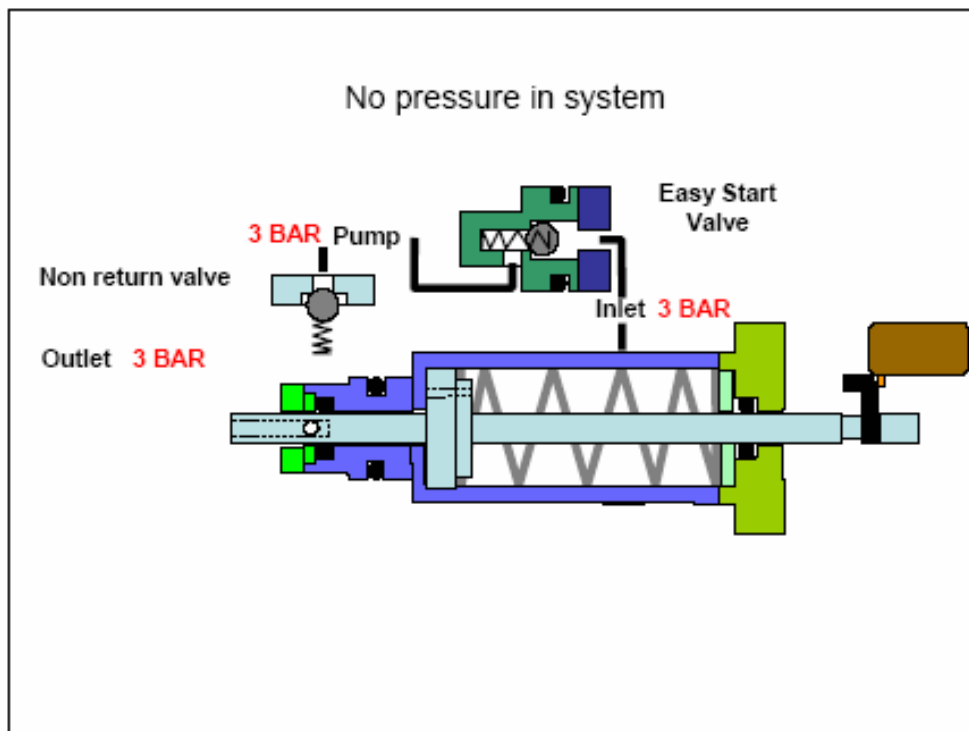

3.2 Start up – pressure build up

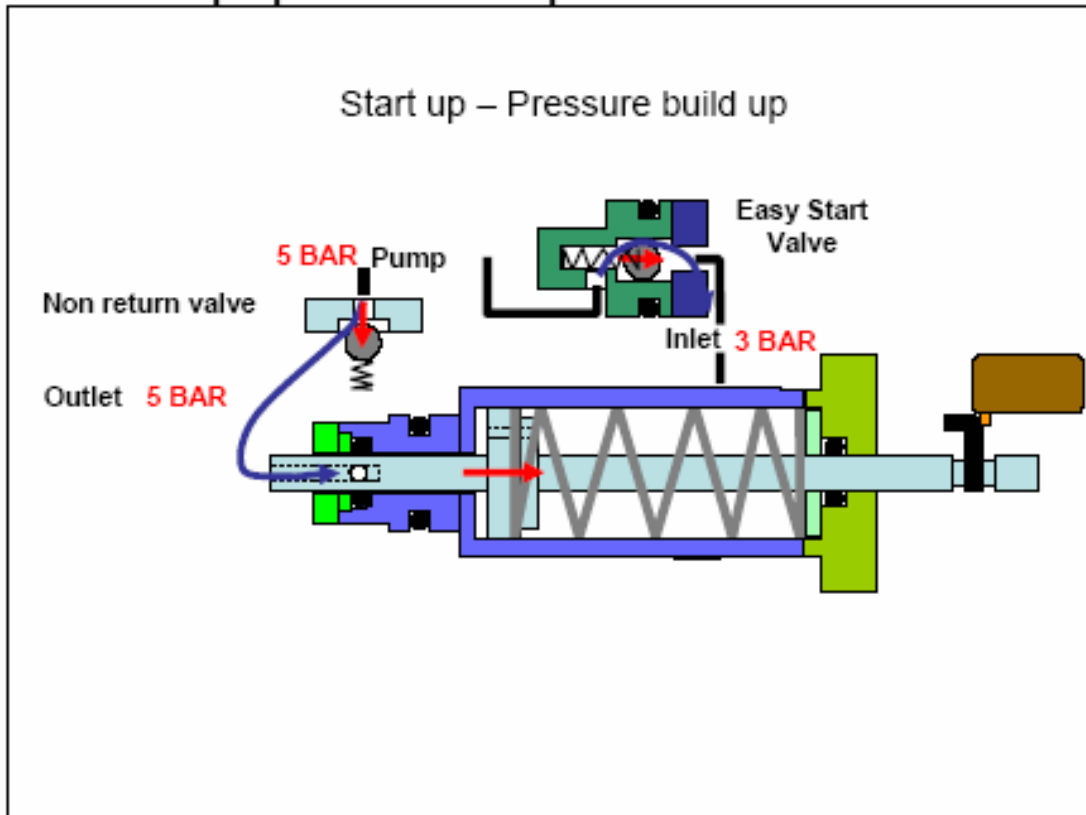

3.3 Pressure builds up. Opening pressure. Microswitch is activated

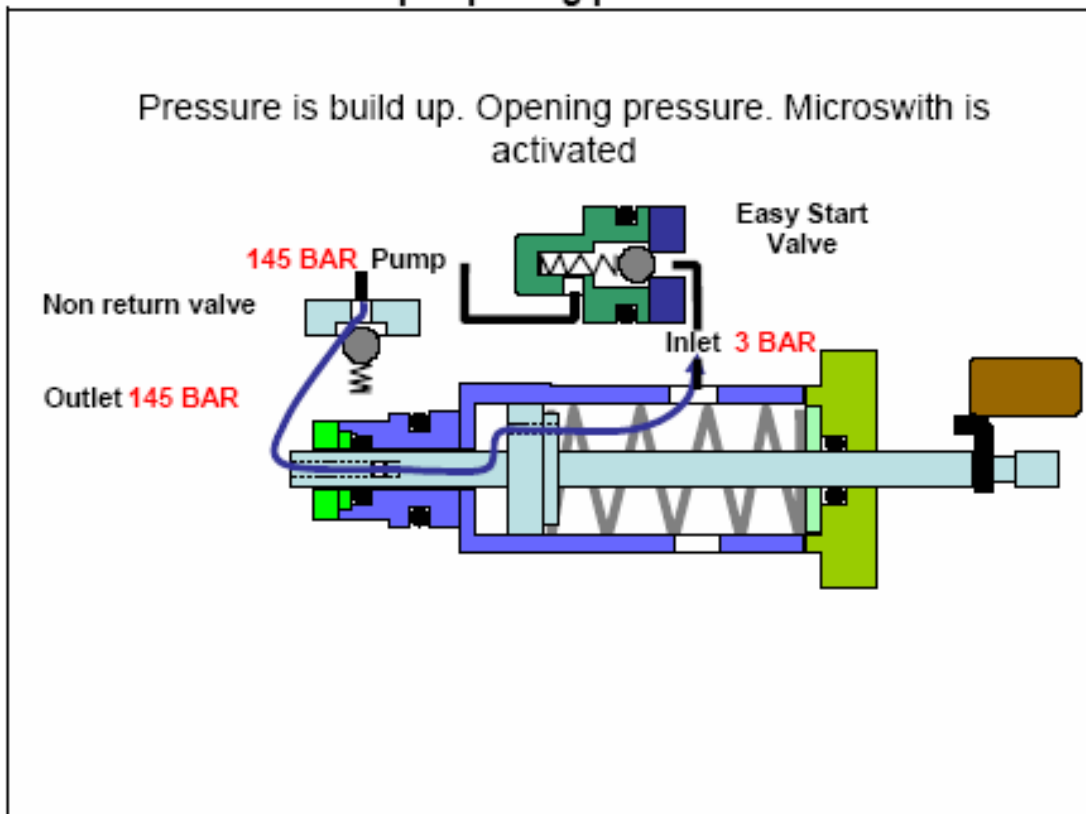

3.4 Motor stop – standby pressure

Motor stops. Pressure in hose decreases to standby pressure. Pump pressure is also standby pressure.

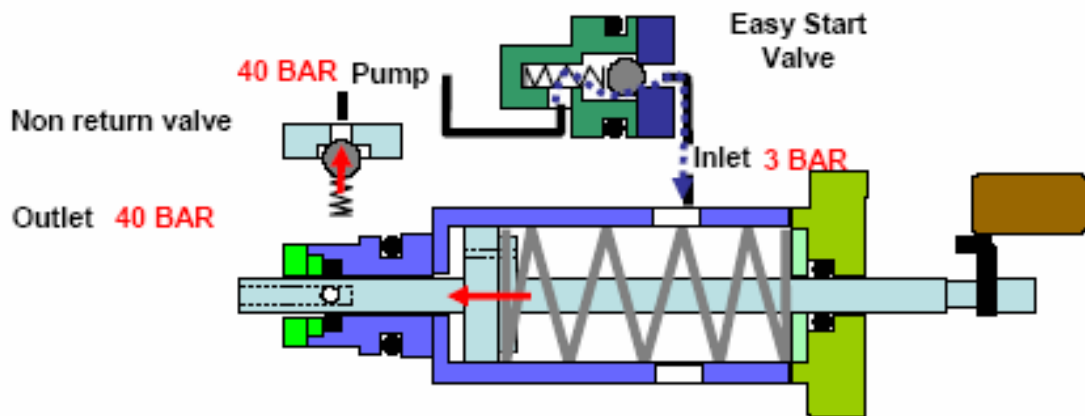

3.5 Pressure in pump during standby pressure

Pressure in pump is now inlet pressure. Easy start valve changes position

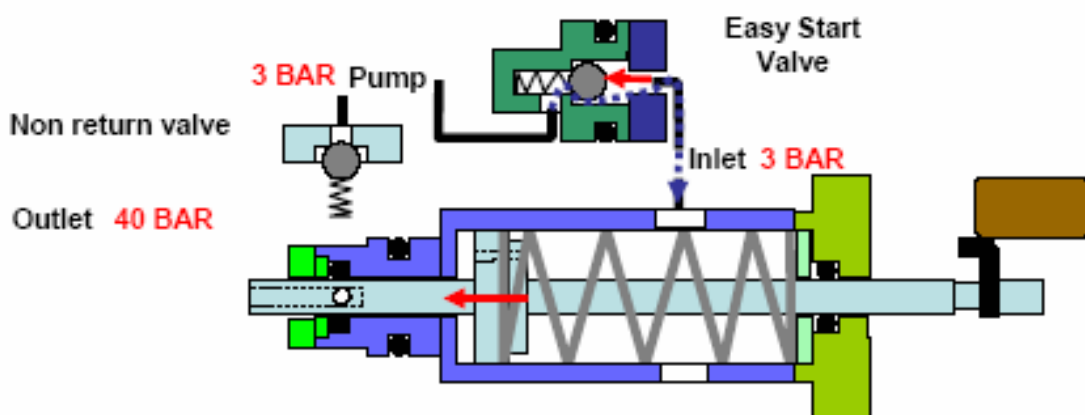

3.6 Gun is activated

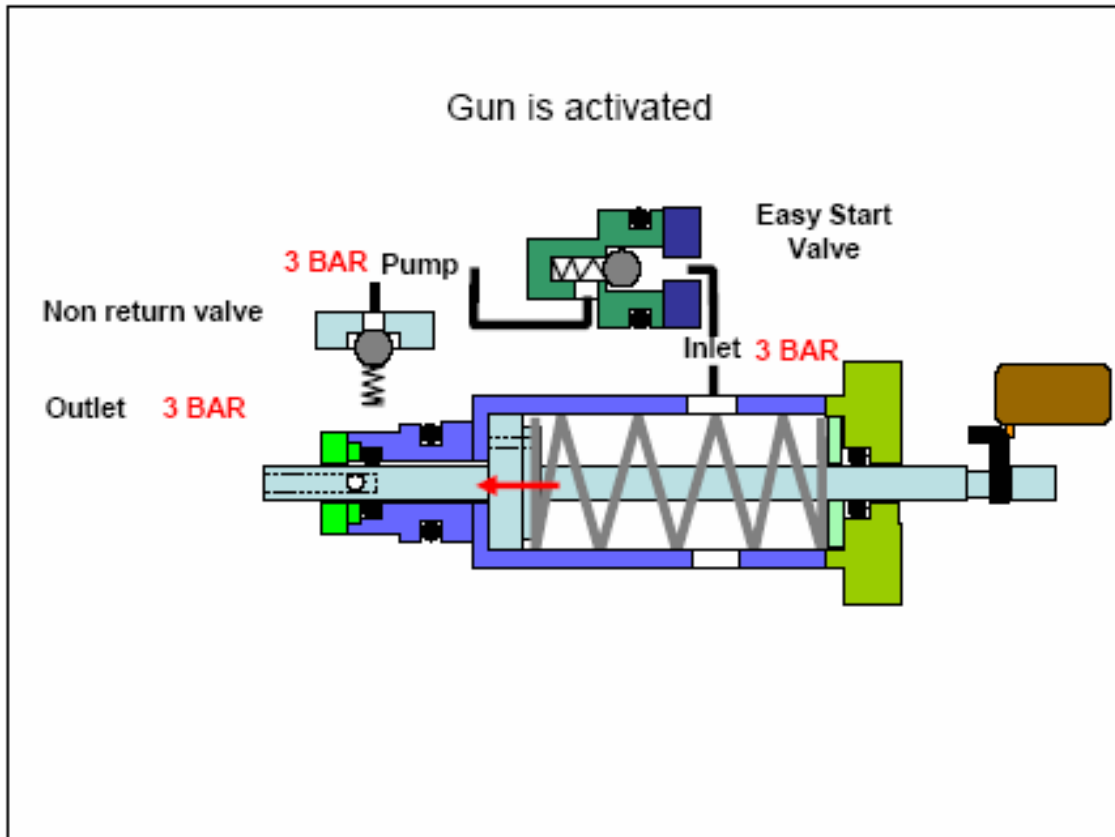

3.7 Machine run

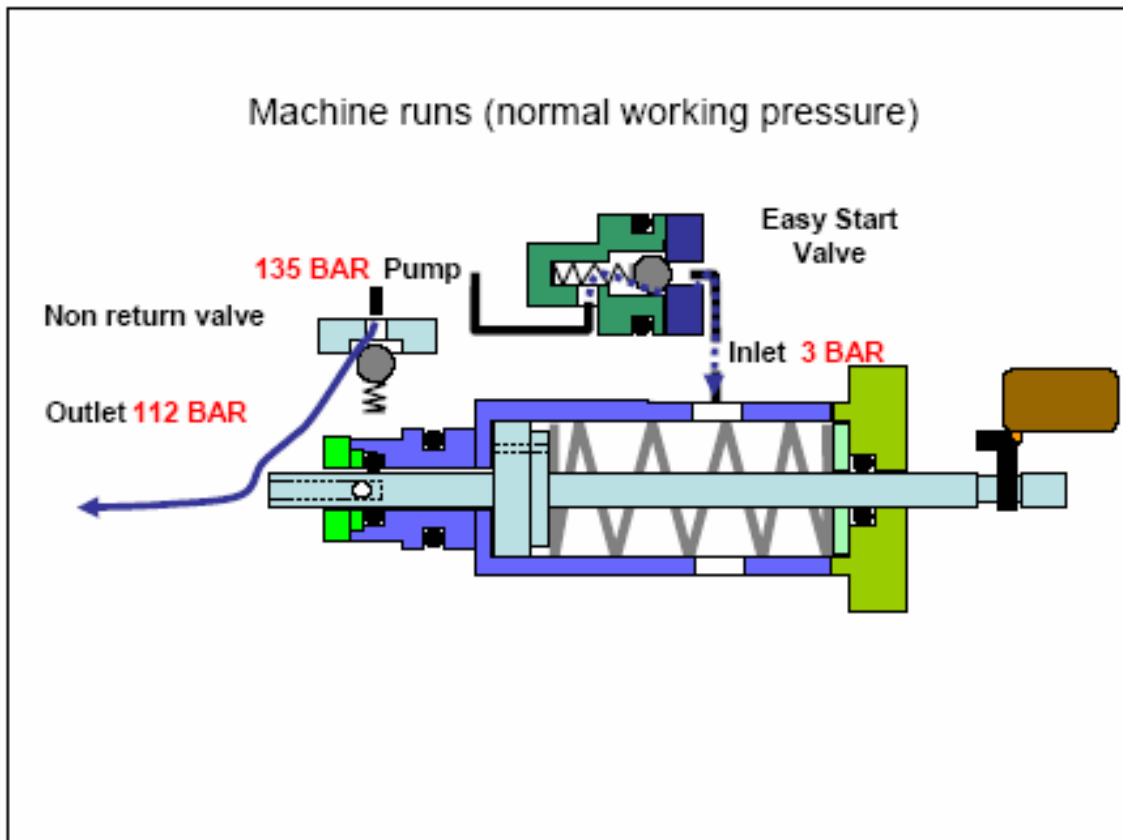

4.0 Easy start guide

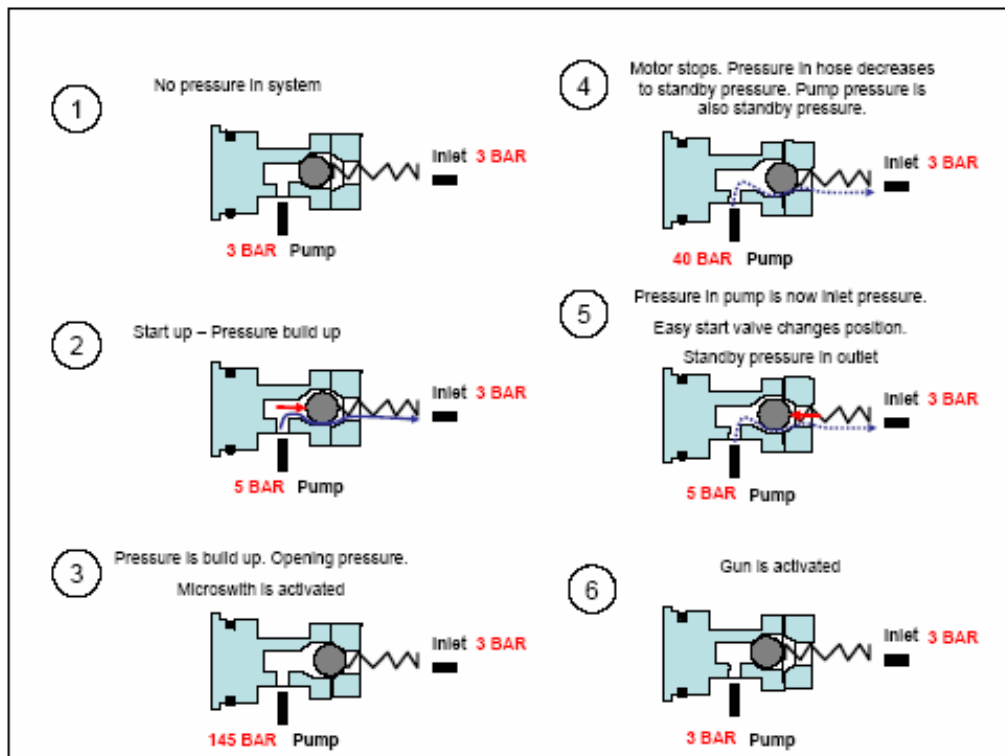

Circuit Diagram

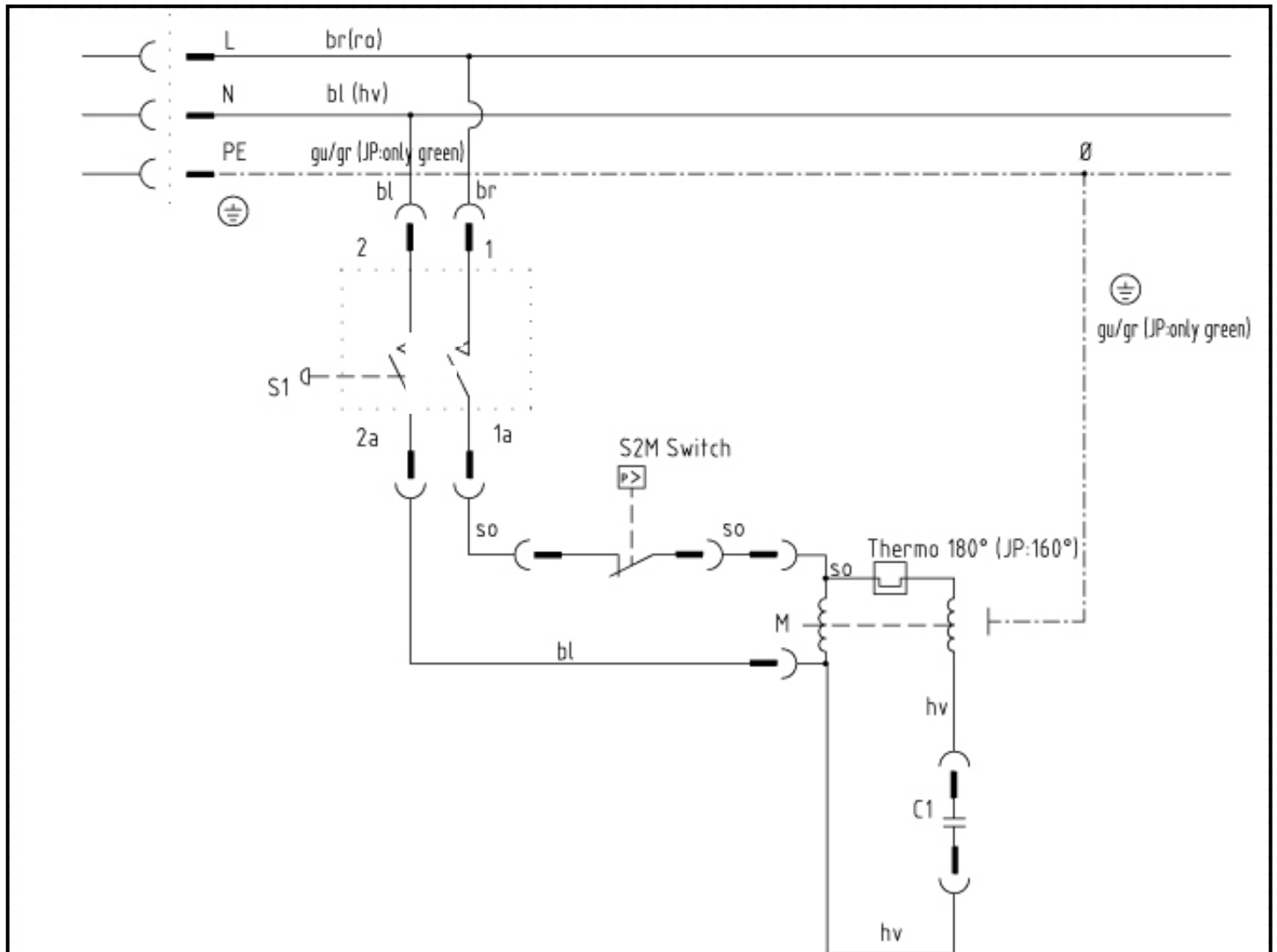

Kredsløbsdiagram - Circuit diagram - Schaltplan - Schema de Circuit électrique

	DANSK	ENGLISCH	DEUTSCH	FRANCAIS
br	Brun	Brown	Braun	Brun
bl	Blå	Blue	Bleu	Bleu
so	Sort	Black	Schwarz	Noir
gu	Gul	Yellow	Gelb	Jaune
gr	Grøn	Green	Grün	Vert
hv	hvid	White	Weiss	Blanc
C1	Kondensator	Capacitor	Kondensator	Condensateur
S1	Afbryder	Switch	Schalter	Disjonteur
S2	Enpolet afbryder/ microswitch	Single-pole switch/ microswitch	Einpolig Schalter/ Microschalter	Disjonteur monopolaire/ Microswitch
M	Motor	Motor	Motor	Moteur

Wiring Diagram

